

TOTOKU

20.1" Monochrome LCD Display

ME201L

20.1 inch Monochrome LCD panel Analog & Digital 1600 x 1200 High Luminance 700 cd/m² 10-bit Display OSD Adjustment VESA Mounting

Specialized videoboard included as standard

Dual Interface High Definition LCD Phenomenally High 1000:1 Contrast



A high definition LCD suited for displaying CT and MRI images and a wide range of modality applications, as well as offering excellent cost performance.

- *High Contrast Large 20.1" LCD with Wide Viewing Angle and High Luminance
- *2 Megapixel Display Resolution from 640 x 480 to 1600 x 1200 (Analog / Digital)
- *High-Density Pixel LCD for High Image Quality
- *Maximum Luminance 700 cd/m² (204fL), Contrast 1000:1
- *Excellent 10-bit (1021-Step Gradation) Gray Scale Display
- *Luminance and Gamma Curve Correction with Calibration Software (Optional)
- *Dual Interface Digital Input (DVI) & Analog Input (D-sub)

● 2 Megapixel High Image Quality Display

Both the digital interface (DVI) and the analog interface (D-sub) achieve a display area of UXGA (1600 x 1200). 2 megapixel high resolution assures high quality images.

● Dual Interface

Digital Visual Interface (DVI) is supported. At the same time, the conventional analog interface (D-sub) is also supported. Analog input using with recommended video card. Digital input using with specialized video card.

● Excellent 10-bit Gamma Gray Scale Display

In the past, LCD displays were only able to process 8 bits (256-level gray scale) of data input from the videoboard, so it was difficult to display smooth gradation. The ME201L expands input data from 8 bits to 10 bits, so it can display more precise gradation.

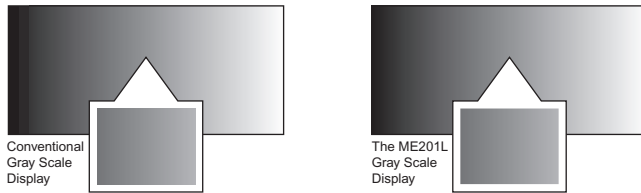

*The images shown are for illustrative purposes and differ from actual images.

● High Precision Luminance Stabilization System

Screen luminance is affected by loss of brightness, due to using the backlight for an extended period of time, and changes in brightness due to temperature. The ME201L employs unique technology to achieve stable luminance that varies little over time and is not affected by temperature changes.

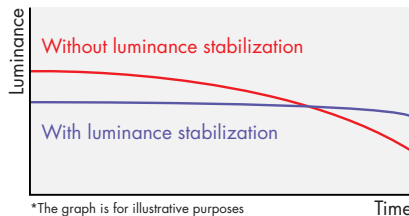

*The graph is for illustrative purposes and differs from actual screen conditions.

● Space-saving Slim Design

The ME201L features an improved space-saving design, including a narrow (20 mm) frame, that makes it less bulky than conventional displays.

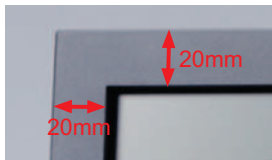

● Medivisor Calibration Software (Optional)

Medivisor calibration software (optional) makes it easy to offset luminance and gamma.

● Compliant with Worldwide Standards

This display is certified to worldwide medical standards. It also complies with the Japanese VCCI standard and the guidelines related to power supply harmonics set forth by the Japan Electronic Industry Development Association.

● VESA Wall Mounting & Arm Mounting Possible

The standard tilt stand can be removed. The display is designed for VESA standard mounting, so it can be wall mounted or used connected to an arm or other equipment.

● ME201L Main Specifications

Model Name	ME201L
LCD panel	20.1" TFT monochrome LCD
	Viewing angle 170° (vertically and horizontally)
	Contrast 1000: 1
Screen display size	Horizontal: 408 mm, vertical: 306 mm (when used horizontally)
Input signal	Digital Input (DVI) / analog input (D-sub)
Resolution	640 x 480 - 1600 x 1200 (analog/digital)
Gray scale display	10-bit (1021-step gradation)
Maximum luminance	700 cd/m ² (204 fL), 450 cd/m ² (131.3 fL) when using calibration
Safety standards	Medical Safety: UL2601-1, CSA No.601.1, MDD / CE (EN60601-1), FDA510 (K) Radio wave (EMC): MDD / CE (EN60601-2), FCC-B, VCCI-B
Dimensions	453 (W) x 466 (H) x 251 (D) mm - landscape 353 (W) x 516 (H) x 251 (D) mm - portrait
Weight	10.5 kg
Body color	Black
Input power supply	100 - 240 V 50/60 Hz
Power consumption	Appr. 50 W (with power management feature)
Calibration control (optional)	Luminance, gamma
Tilting base	Tilting / swiveling base with vertical, horizontal, and rotating features
Other features	On Screen Display (OSD), DDC2B, RS232C, USB hub
Compatible OS	Microsoft Windows NT 4.0 / Windows 2000
Accessories	AC adapter, power cord, operation manual, DVI cable, VGA cable, Specialized videoboard

*These specifications are accurate as of September 2002. They are subject to change without notice.

● ME201L Size

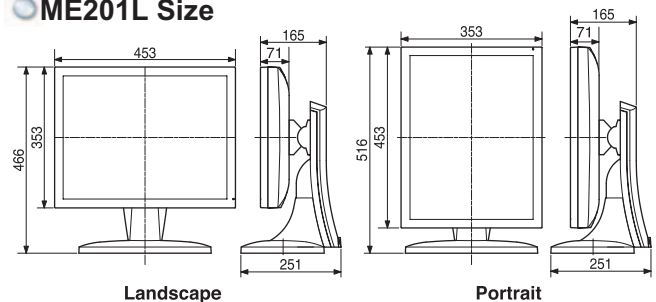

Totoku Electric Co., Ltd. is certified to ISO 14000 for environmental management and ISO 9001 for quality assurance.



JQA-EM0674



JQA-0679



Safety Precautions

To ensure safe use of this product, read "Operation Manual / Safety" before using the product.

Do not install the product in areas where it may be affected by water, dust, humidity, oil or smoke. Storing the product in such conditions could cause a fire, equipment failure or electrical shock.

TOTOKU

Sales Department MM Company
Totoku Electric Co., Ltd.

TEL: +81 3-5273-2053 FAX: +81 3-5273-2091
1-3-21 Okubo, Shinjuku-ku, Tokyo 169-8543

*USA office: +469-442-0112
*EUROPE office: +49-173-2522589

*The most current information is provided on the internet, at <http://www.totoku.com/dp/>.

*Company names and product names are the trademarks or registered trademarks of the respective companies. *Product specifications and appearances are subject to change without notice. *Colors in photographs differ from actual colors due to the printing process.

Please contact the distributor below with inquiries and orders.